

FEATURES & BENEFITS

Broadband performance with low reflection DC to 4 GHz provides low cost connector combined with high quality.

Quick connect/disconnect snap-on mating reduces installation time.

Various plating options in nickel, gold, and tin. Selective plating provides corrosion resistance finish as well as good solderability characteristics.

SMB PCB slide-on plug and jack allows board-to-board mounting with a low insertion force. This is ideal for mating a high number of connectors on a pair of PCB's.

APPLICATIONS

**Automotive
Base Stations
Cable Assemblies
Components
Instrumentation
PC/LAN
Process Controls
Radio Boards
Surge Protection
Telecom
Test and Measurement
Video Systems**



SMB Connectors

The SMB name derives from SubMiniature B (the second subminiature design). Developed in the 1960's, the interface has both snap-on and slide-on couplings. Amphenol's SMB connectors conform to the requirements of MIL-C-39012, and the interface is in compliance with MIL-STD-348. Available in 50 Ω and 75 Ω , the SMB provides broadband capability through 4 GHz with a snap-on connector design and utilizes die cast components on non-critical areas to provide a low-cost solution.

50 Ω SMB Specifications

Electrical

Impedance	50 Ω
Frequency Range	0-4 GHz with low reflection; can be used up to 10.0 GHz
Voltage Rating for RG-188/U Cable	335 volts at sea level and 85 volts at 70,000 feet
Dielectric Withstanding Voltage	RG-196: 750 VRMS; RG-188: 1,000 VRMS
VSWR	Straight connector, RG-196/U: 1.30 + .04 f (GHz) Right angle connector, RG-196/U: 1.45 + .06 f (GHz) Straight connector, RG-188/U: 1.25 + .04 f (GHz) Right angle connector, RG-188/U: 1.35 + .04 f (GHz)
Contact Resistance	Center contact: 6.0 m Ω initial, 8.0 after environmental; Outer contact: 1.0 m Ω initial, 1.5 after environmental; Braid to body: 1.0 m Ω initial, after environmental N/A
Insulation Resistance	1,000 M Ω minimum
Insertion Loss	Straight connector: 0.30 dB @ 1.5 GHz Right angle connector: 0.60 dB @ 1.5 GHz
RF Leakage	-55 dB minimum @ 2-3 GHz

Mechanical

Mating	Snap-on coupling per MIL-STD-348
Braid/Jacket Cable Affixment	Hex crimp
Center Conductor Cable Affixment	Solder
Contact Captivation	All types unless noted otherwise
Cable Retention	Equal to breaking strength of cable employed
Engagement Forces	Engagement: 14 lbs maximum Disengagement: 2 lbs minimum After 500 matings, 14 lbs maximum engagement and disengagement
Connector Durability	500 mating cycles minimum

Material

Center Contact	Female: beryllium copper, gold-plated Male: brass or beryllium copper, gold-plated
Outer Contact Plating	Nickel or gold plating as indicated
Body	Brass per QQB-626, or zinc per ASTM B86-71
Body Plating	Nickel or gold plating as indicated
Insulator	PTFE
Crimp Ferrule	Annealed copper alloy

Environmental

Temperature Range	-65°C to + 165°C
Thermal Shock	MIL-STD-202 method 107, test condition B (except high temperatures @ 200°C)
Shock	MIL-STD-202 method 202, method 13, snap-on, test condition B; 75 G's @ 6 milliseconds ½ sine
Vibration	MIL-STD-202 method 204, snap-on, test condition B; (15 G's)
Corrosion	MIL-STD-202 method 101, test condition B. 5% salt solution

PLUG

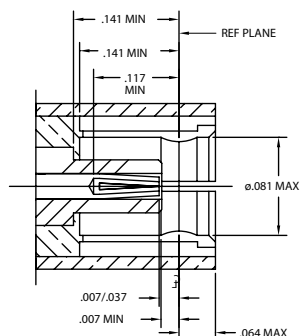

JACK

