

REV.	DATE	ECR NO.	DESCRIPTION
NC	03/03/09	-	INITIAL RELEASE

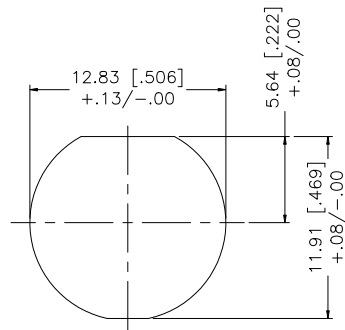

RECOMMENDED MOUNTING HOLE

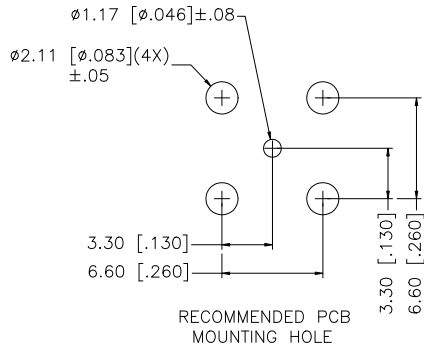
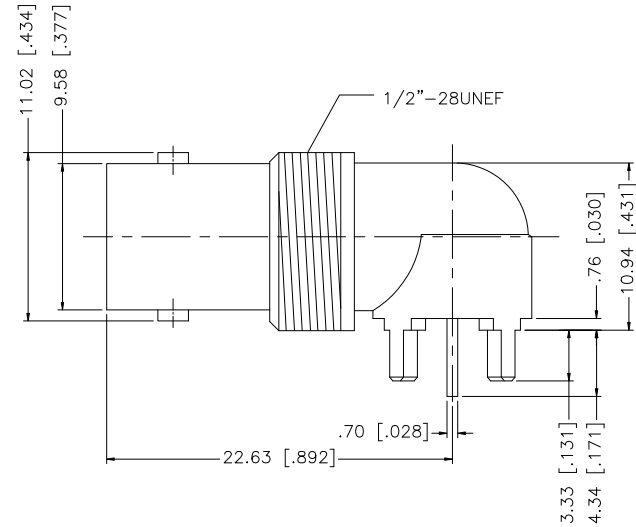
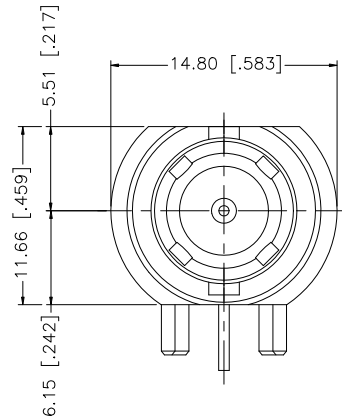

RECOMMENDED PCB MOUNTING HOLE

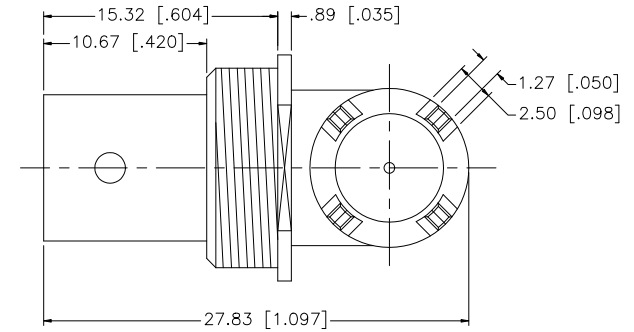
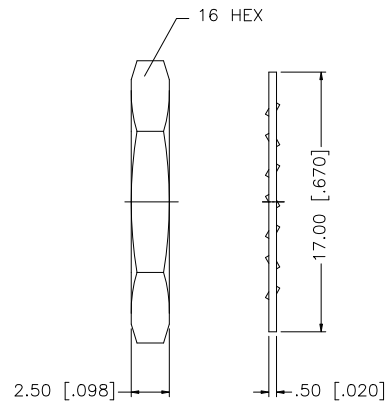

DESCRIPTION	MATERIAL	FINISH	QTY
8			
7			
6	HEX NUT	BRASS	NICKEL 1
5	LOCK WASHER	BRASS	NICKEL 1
4	CONTACT PIN	PHOS. BRONZE	GOLD 1
3	INSULATOR	DELTRIN	NATURAL 2
2	INSULATOR	PTFE	NATURAL 1
1	BODY	ZINC DIE CAST	NICKEL 1

UNLESS OTHERWISE SPECIFIED DIMENSIONS ARE IN MILLIMETERS. DIMENSIONS IN [] ARE IN INCHES AND FOR CUSTOMER REFERENCE ONLY.

UNLESS OTHERWISE SPECIFIED TOLERANCES FOR MILLIMETERS ARE:
0.5 - 8mm ± 0.20mm
8 - 30mm ± 0.40mm
30 - 120mm ± 0.50mm

UNLESS OTHERWISE SPECIFIED TOLERANCES FOR INCHES ARE:
.020 - .315 = ± 0.007"
.315 - 1.180 = ± 0.015"
1.180 - 4.724 = ± 0.020"

DO NOT SCALE DRAWING

APPROVALS	DATE
DRAWN GRS	03/03/09
CHECKED	
ISSUED	
SHEET 1 OF 1	
CAD FILE	C:/112/112760-10.DWG

Amphenol Connex

PART DESCRIPTION

BNC R/A P.C. JACK
LOW PROFILE

PART NO.

112760-10

DWG. NO.

112760-10.DWG

REV. NC

SIZE A

SCALE NA