

NOTES:

1. MATERIALS AND FINISHES:
 SHELL - BRASS, NICKEL PLATING
 GASKET - SILICONE RUBBER, RED
 RIVET - BRASS, NICKEL PLATING
2. MECHANICAL:
 A. DURABILITY: 500 CYCLES MIN.
 B. TEMPERATURE RANGE: -65°C TO 165°C
3. PACKAGING:
 A. QUANTITY: SINGLE PACK
 B. MARKING: PACKAGING TO BE MARKED
 "AMPHENOL RF, 222145-10, AND DATE CODE"

REVISIONS				
REV	DESCRIPTION	DATE	ECN	BY
NC	INITIAL RELEASE	06/29/08	-----	GRS
A	RIVET ADDED TO CAP	09-JAN-26	17717	LQ

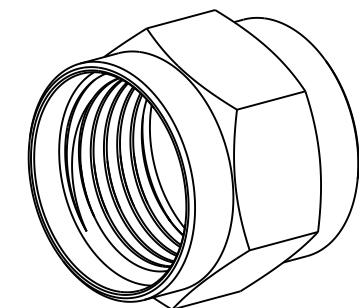
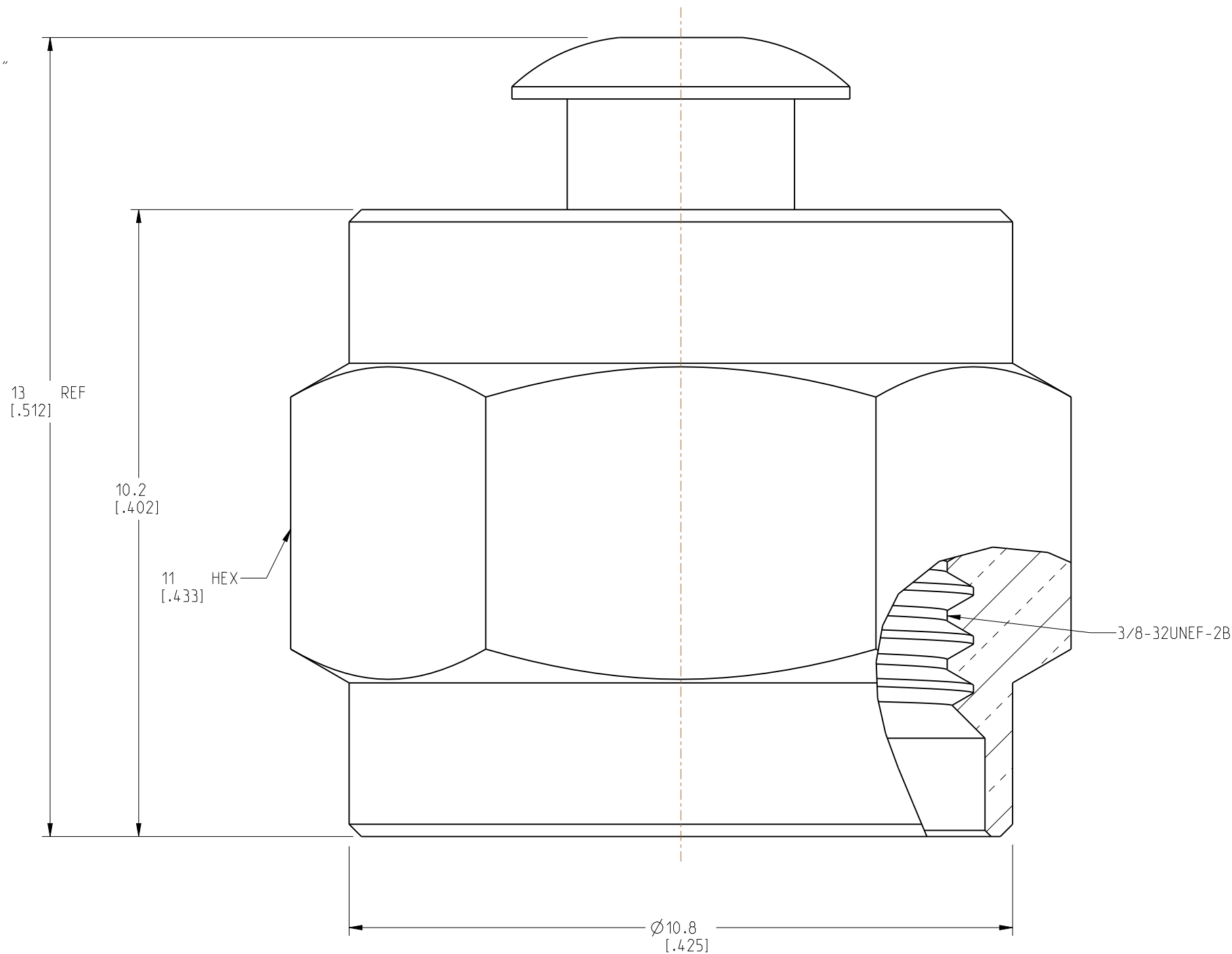

CUSTOMER OUTLINE DRAWING

ALL OTHER SHEETS ARE FOR INTERNAL USE ONLY

NOTICE: These drawings, specifications, or other data (1) are, and remain the property of Amphenol corp. (2) must be returned upon request; and (3) are confidential and not to be disclosed to any person other than those to whom they are given by Amphenol Corp. The furnishing of these drawings, specifications, or other data by Amphenol Corp., or to any other person to anyone for any purpose is not to be regarded by implication or otherwise in any manner licensing, granting rights to permitting such holder or any other person to manufacture, use or sell any product, process or design, patented or otherwise, that may in any way be related to or disclosed by said drawings, specifications, or other data.		UNLESS OTHERWISE SPECIFIED DIMENSIONS ARE METRIC (INCHES) AND TOLERANCES ARE: <0.5mm = ±0.05mm [$<0.020 = \pm 0.002$] 0.5 - 6mm = ±0.1mm [$>0.020 - 0.236 = \pm 0.004$] >6.00 - 30mm = ±0.2mm [$>0.236 - 1.181 = \pm 0.008$] >30.00 - 120mm = ±0.3mm [$>1.181 - 4.725 = \pm 0.012$] ANGLES = ±1°		MATERIAL SEE NOTES		TITLE F MALE CAP W/O CHAIN		Amphenol RF	
THIRD ANGLE PROJ.		REFERENCE F500-003-N		EAR# 13152		ENGR.1 P.SALOMAO		ENGR.2 M.ZHANG	
				DATE 06-JAN-26		SHEET NO. 2 OF 2		SCALE: 12.0:1.0	
						SIZE B		DRAWING NO. 222145-10 ITEM NO. 222145-10 PART NO. 222145-10	
								REV A	