

NOTES:

- MATERIALS AND FINISHES:
 MMCX STR PLUG - BRASS, GOLD PLATING
 RP SMA STR BHD JACK IP 67 - BRASS, GOLD PLATING
 CABLE - RG 178
- ELECTRICAL:
 A. IMPEDANCE: 50 OHM
- PACKAGING:
 A. QUANTITY: SINGLE PACK
 B. MARKING: BAG TO BE MARKED
 "AMPHENOL RF, 95-900-619-XXX AND DATE CODE"

REVISIONS				
REV	DESCRIPTION	DATE	ECN	BY
A	RELEASE TO MFG.	24-APR-26	17872	RS

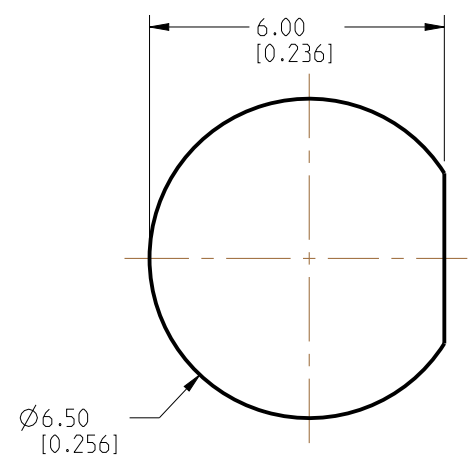
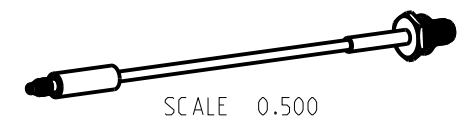

RECOMMENDED MOUNTING HOLE DIMENSIONS

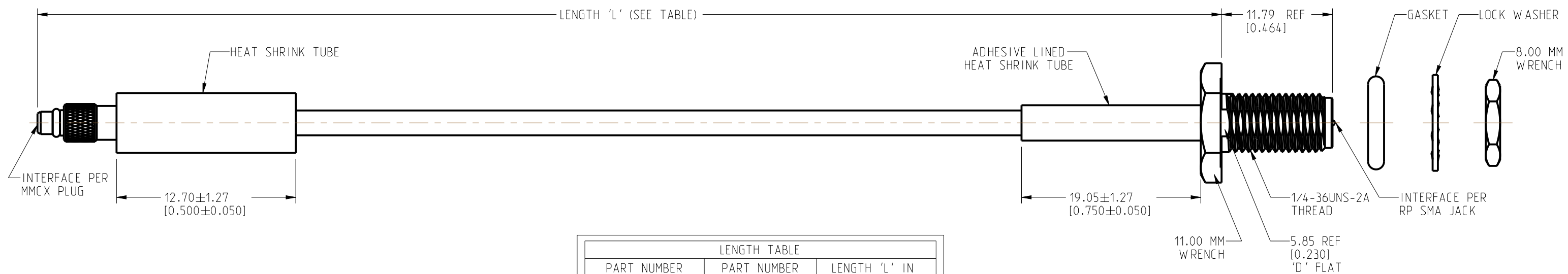

LENGTH TABLE		
PART NUMBER (IMPERIAL)	PART NUMBER (METRIC)	LENGTH 'L' IN INCHES (METERS)
95-900-619-003	-	3.00 [0.076]
95-900-619-004	-	4.00 [0.102]
95-900-619-005	-	5.00 [0.127]
95-900-619-006	-	6.00 [0.152]
95-900-619-007	-	7.00 [0.178]
95-900-619-008	-	8.00 [0.203]
95-900-619-009	-	9.00 [0.229]
95-900-619-010	-	10.00 [0.254]
95-900-619-011	-	11.00 [0.279]
95-900-619-012	-	12.00 [0.305]
95-900-619-018	-	18.00 [0.457]
95-900-619-024	-	24.00 [0.610]
95-900-619-036	-	36.00 [0.914]
-	95-900-619M100	39.37 [1.000]
95-900-619-048	-	48.00 [1.219]

TOLERANCE TABLE	
LENGTH IN INCHES/FT [METERS]	TOLERANCE
0" - 23.99" [0 - 0.609]	±0.25" [0.006]
24.00" - 59.99" [0.610 - 1.523]	±0.50" [0.013]
5.0' - 24.99' [1.524 - 7.617]	±2.5%
25.0' & UP [7.620 & UP]	±5.0%

DESIGN REQUIREMENTS:

<input checked="" type="checkbox"/> FREQUENCY: DC - 6 GHz	<input checked="" type="checkbox"/> CONTINUITY
<input type="checkbox"/> VSWR: _____ 1 MAX.	<input checked="" type="checkbox"/> HI-POT: 300 VRMS
<input type="checkbox"/> INS. LOSS: _____ dB MAX.	<input type="checkbox"/> OTHER

CUSTOMER OUTLINE DRAWING
 ALL OTHER SHEETS ARE FOR INTERNAL USE ONLY

NOTICE: These drawings, specifications, or other data (1) are, and remain the property of Amphenol corp. (2) must be returned upon request; and (3) are confidential and not to be disclosed to any person other than those to whom they are given by Amphenol Corp. The furnishing of these drawings, specifications, or other data by Amphenol Corp., or to any other person to anyone for any purpose is not to be regarded by implication or otherwise in any manner licensing, granting rights to permitting such holder or any other person to manufacture, use or sell any product, process or design, patented or otherwise, that may in any way be related to or disclosed by said drawings, specifications, or other data.		UNLESS OTHERWISE SPECIFIED DIMENSIONS ARE METRIC [INCHES] AND TOLERANCES ARE: <0.5mm = ±0.05mm [-0.020 = ±0.002] 0.5 - 6mm = ±0.1mm [-0.020 - 0.236 = ±0.004] >6.00 - 30mm = ±0.2mm [-0.236 - 1.181 = ±0.008] >30.00 - 120mm = ±0.3mm [-1.181 - 4.725 = ±0.012]		MATERIAL SEE NOTES		TITLE MMCX STR PLUG TO RP SMA STR BHD JACK IP 67 USING RG 178 CABLE		Amphenol RF	
THIRD ANGLE PROJ.		REFERENCE		ENGR.1 SIBI R		ENGR.2		DATE 13-OCT-25	
EAR# 13261		ANGLES = ±1°		SHEET NO. 2 OF 2		SCALE: 2.5:1.0		DRAWING NO. 95-900-619-XXX ITEM NO. 95-900-619-XXX PART NO. 95-900-619-XXX	