

NOTES:

1. MATERIALS AND FINISHES:  
 BODY - STAINLESS STEEL, PASSIVATED  
 BODY & CONTACT - BeCu, GOLD PLATING  
 INSULATOR - ULTEM 1000, NATURAL  
 INSULATOR DISC - PTFE, NATURAL
2. ELECTRICAL:  
 A. IMPEDANCE: 50 OHM  
 B. FREQUENCY RANGE: DC - 40 GHz  
 C. VSWR: 1.25 MAX.  
 D. DIELECTRIC WITHSTANDING VOLTAGE: 500 VRMS, MIN.
3. MECHANICAL:  
 A. DURABILITY:  
   2.92 MM SIDE : 500 CYCLES MIN.  
   SMPM SIDE : 100 CYCLES MIN.  
 B. TEMPERATURE RANGE: -65°C TO +165°C
4. PACKAGING:  
 A. QUANTITY: SINGLE PACK  
 B. MARKING: PACKAGING TO BE MARKED  
   "AMPHENOL RF, AD-292JSMPMP-1 AND DATE CODE"

REVISIONS				
REV	DESCRIPTION	DATE	ECN	BY
A	RELEASE TO MFG.	20-MAY-26	17903	KR

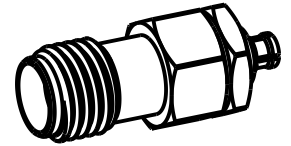

SCALE 2.000

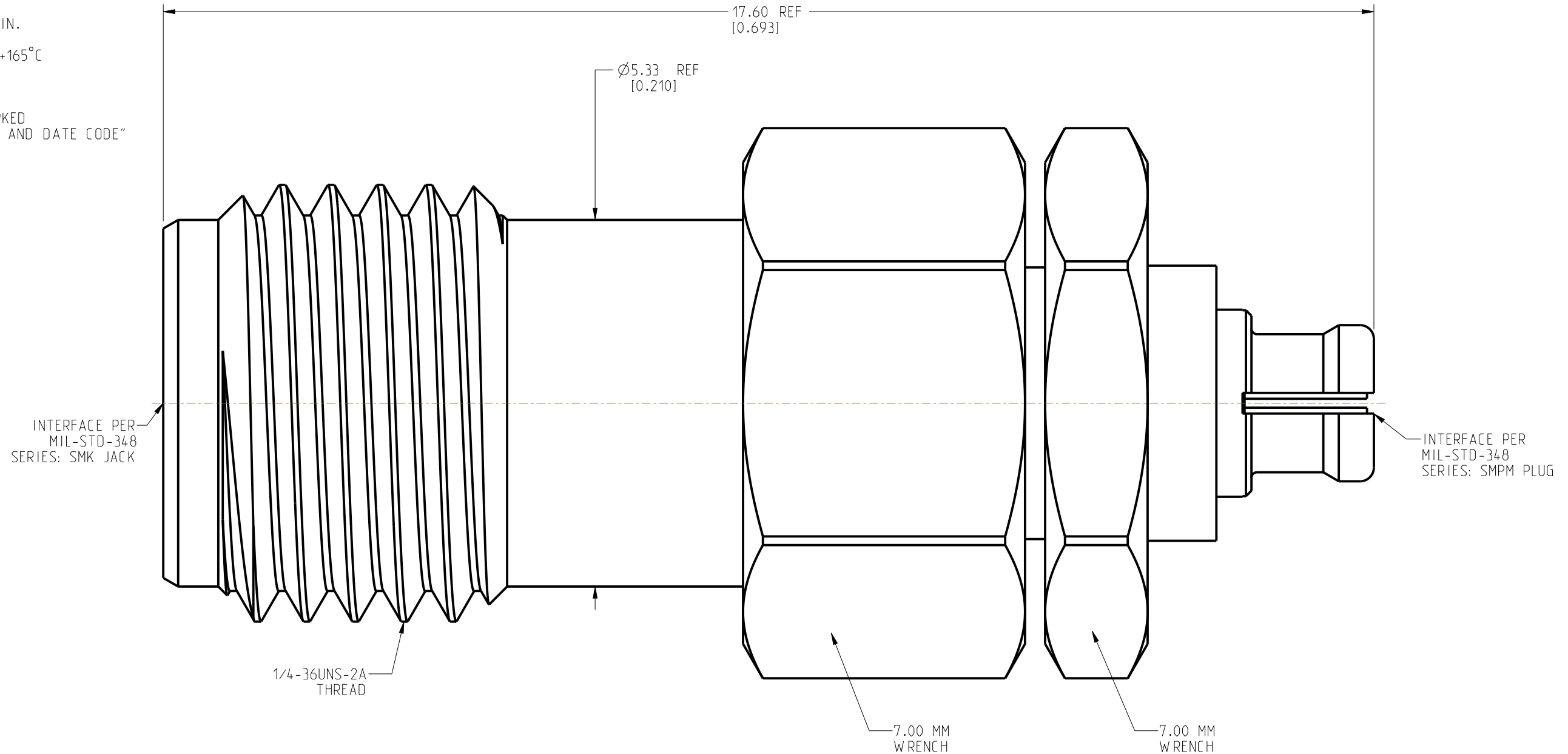

**CUSTOMER OUTLINE DRAWING**

ALL OTHER SHEETS ARE FOR INTERNAL USE ONLY

NOTICE: These drawings, specifications, or other data (1) are, and remain the property of Amphenol corp. (2) must be returned upon request; and (3) are confidential and not to be disclosed to any person other than those to whom they are given by Amphenol Corp. The furnishing of these drawings, specifications, or other data by Amphenol Corp., or to any other person to anyone for any purpose is not to be regarded by implication or otherwise in any manner licensing, granting rights to permitting such holder or any other person to manufacture, use or sell any product, process or design, patented or otherwise, that may in any way be related to or disclosed by said drawings, specifications, or other data.		UNLESS OTHERWISE SPECIFIED DIMENSIONS ARE METRIC (INCHES) AND TOLERANCES ARE: <0.5mm = ±0.05mm [ $<0.020 = \pm 0.002$ ] 0.5 - 6mm = ±0.1mm [ $>0.020 - 0.236 = \pm 0.004$ ] >6.00 - 30mm = ±0.2mm [ $>0.236 - 1.181 = \pm 0.008$ ] >30.00 - 120mm = ±0.3mm [ $>1.181 - 4.725 = \pm 0.012$ ]		MATERIAL SEE NOTES		TITLE 2.92MM STR JACK TO SMPM PLUG ADAPTER		<b>Amphenol RF</b>	
THIRD ANGLE PROJ.		REFERENCE		ENGR.1 R KARTHIK		ENGR.2 JACK LIANG		DATE 10-JUL-24	
EAR# 12355		ANGLES = ±1°		SHEET NO. 2 OF 2		SCALE: 15.0:1.0		DRAWING NO. AD-292JSMPMP-1 ITEM NO. AD-292JSMPMP-1 PART NO. AD-292JSMPMP-1	
								REV A	